

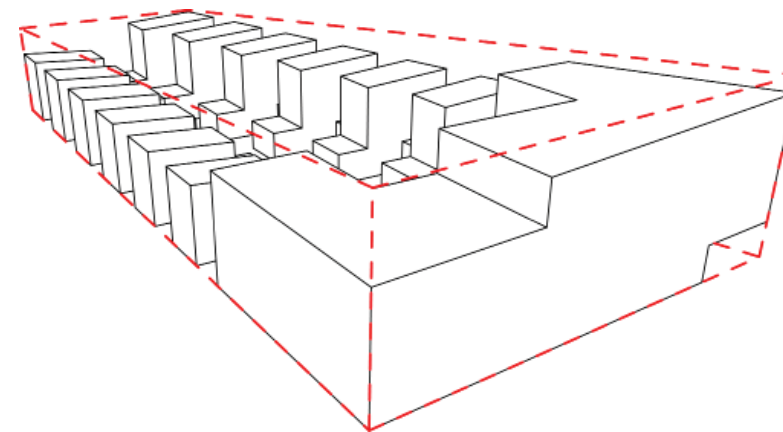

KLEVARIE MAASTRICHT Blok A 08 December 2016

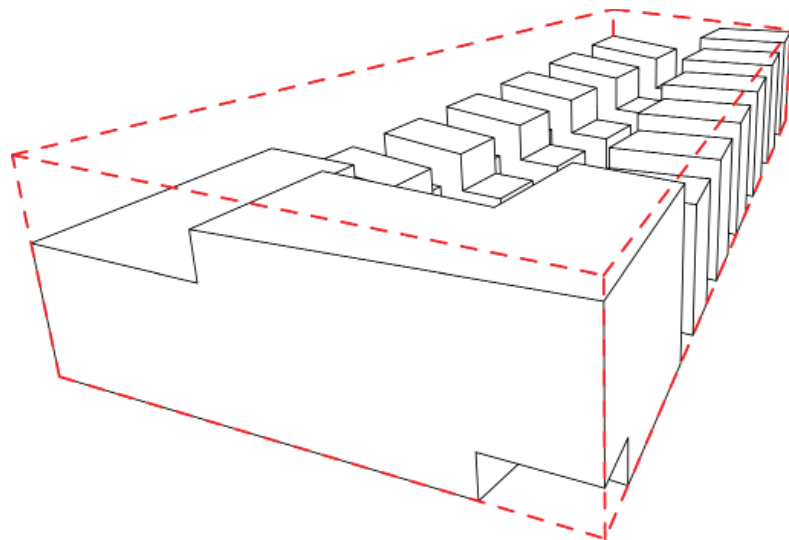

BLOK A

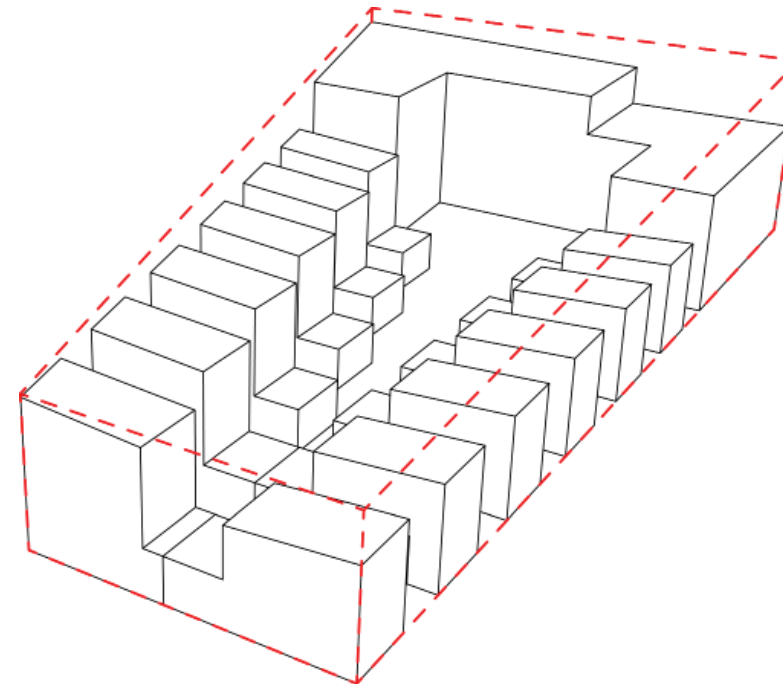
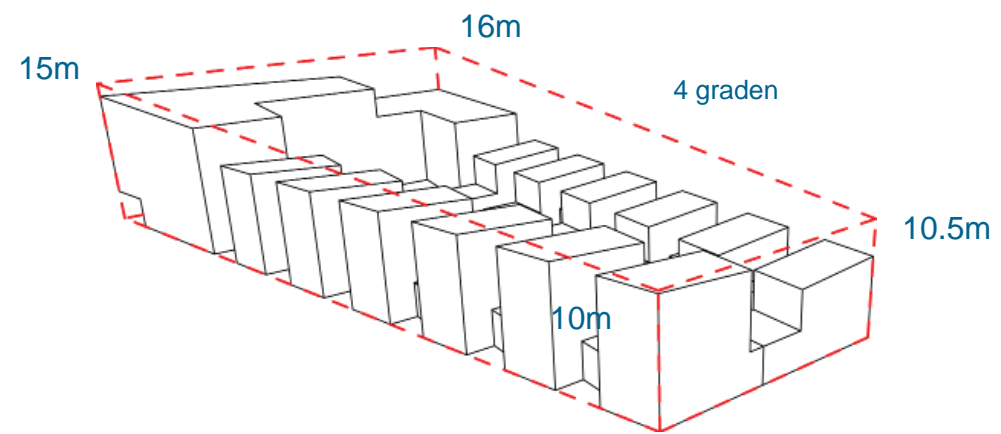

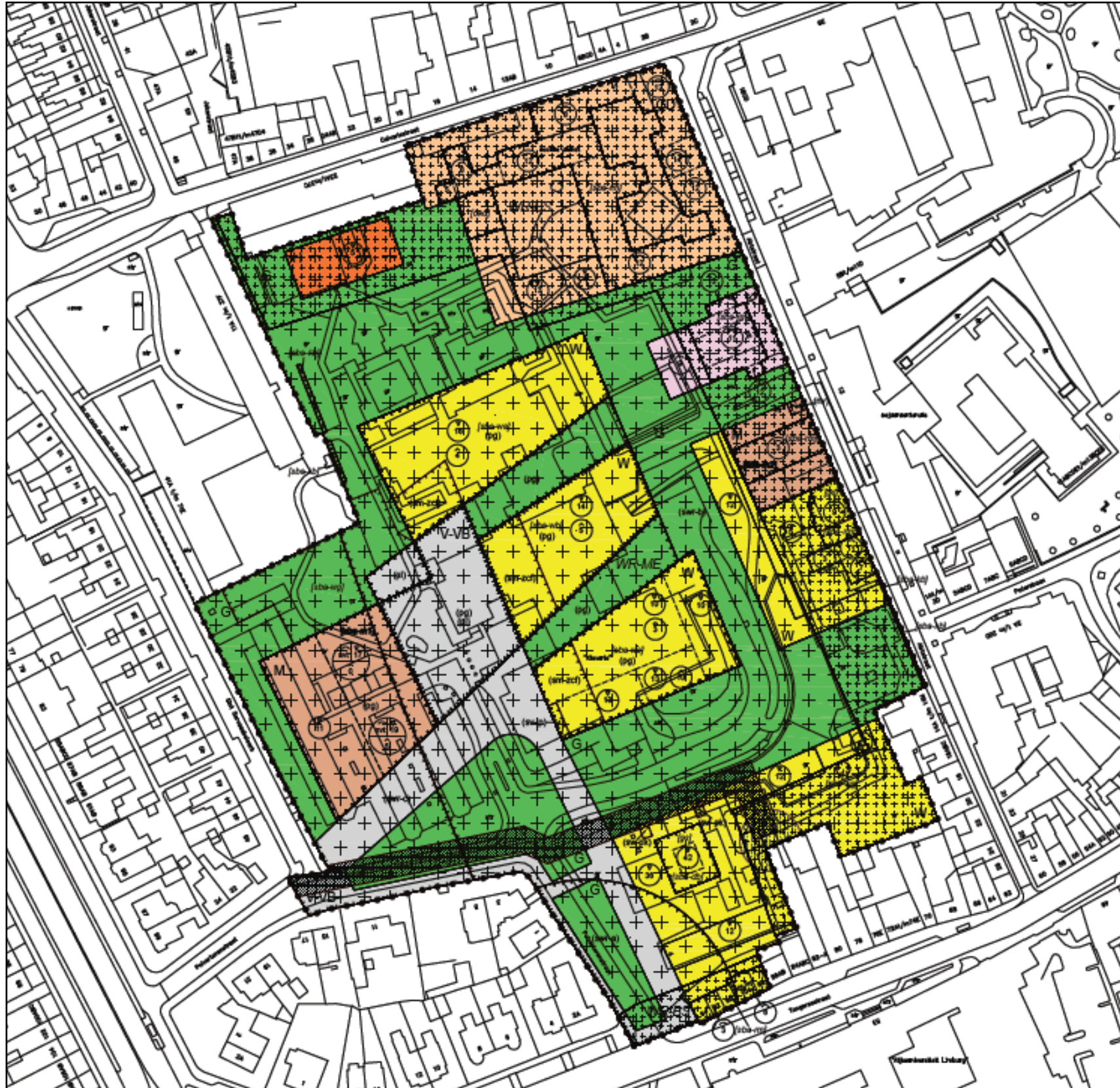

BESTEMMINGSPLAN KAART

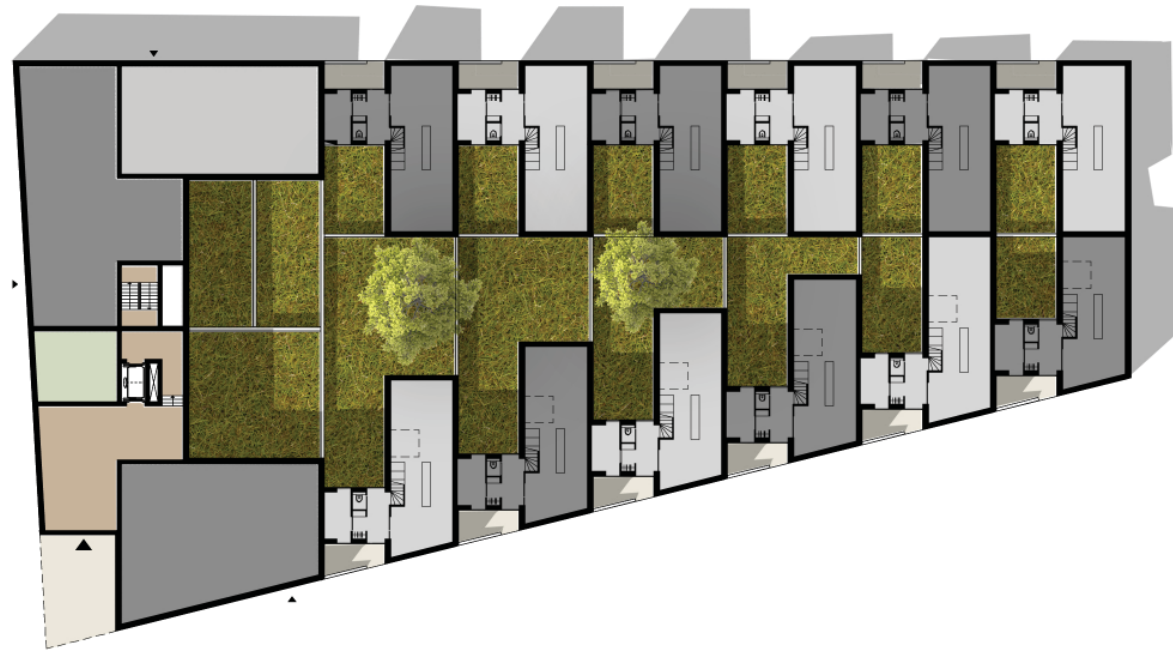

begane grond



verdieping 1

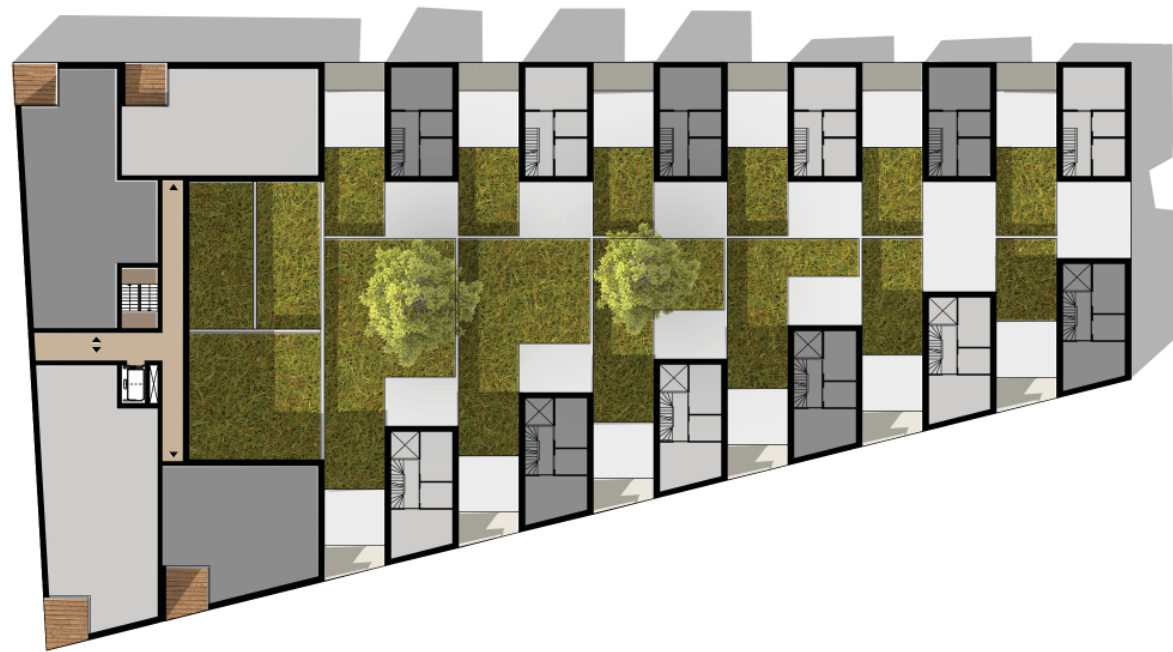

verdieping 2

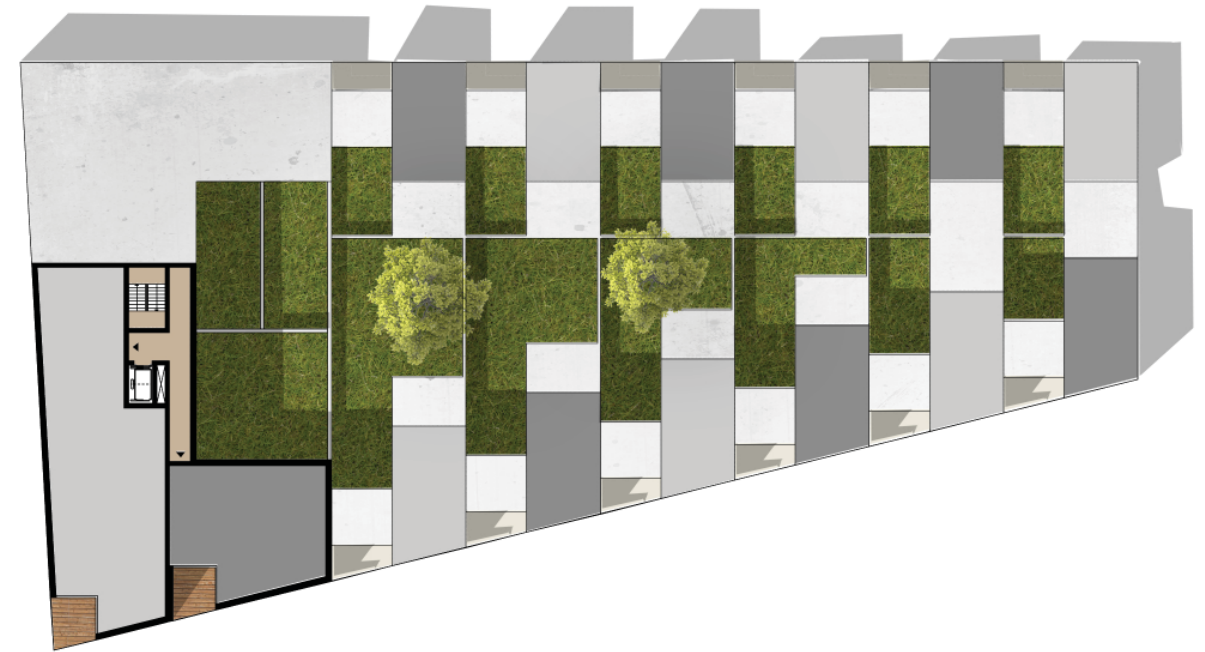

verdieping 3

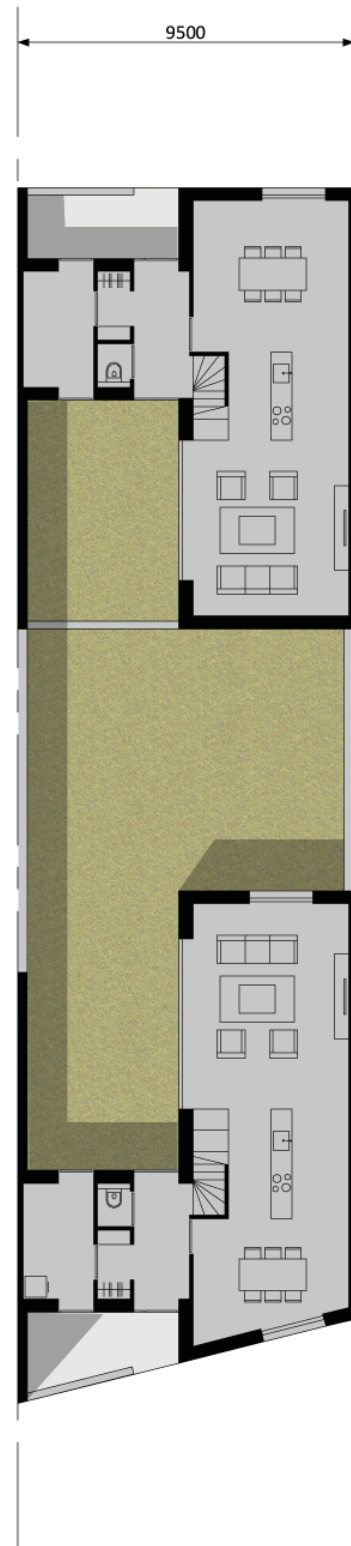

woning basis

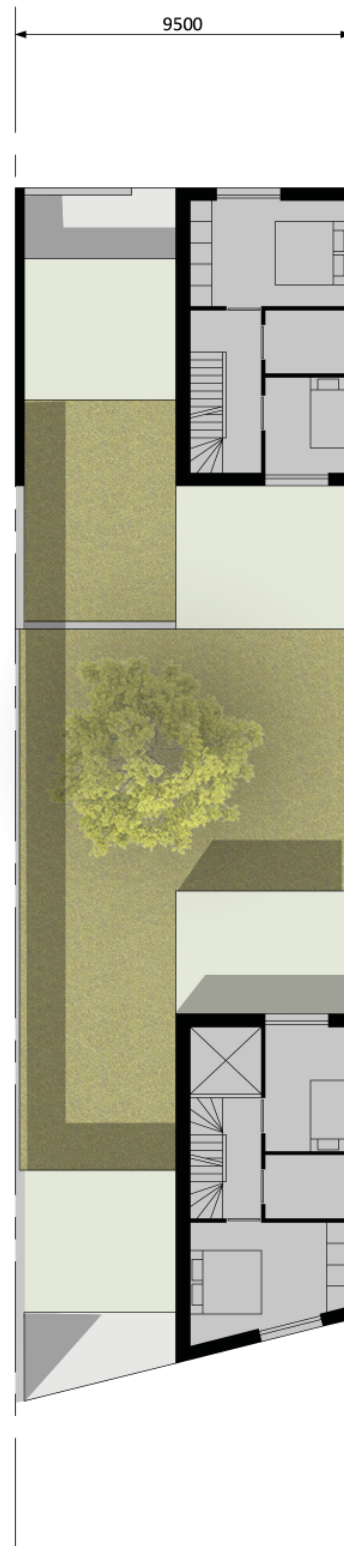

verdieping basis

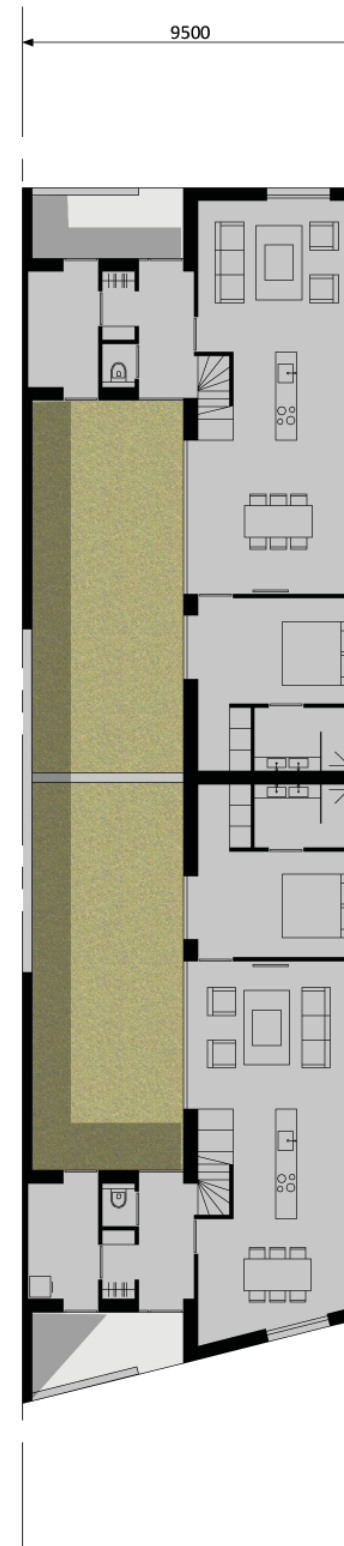

optie: levensloopbestendig

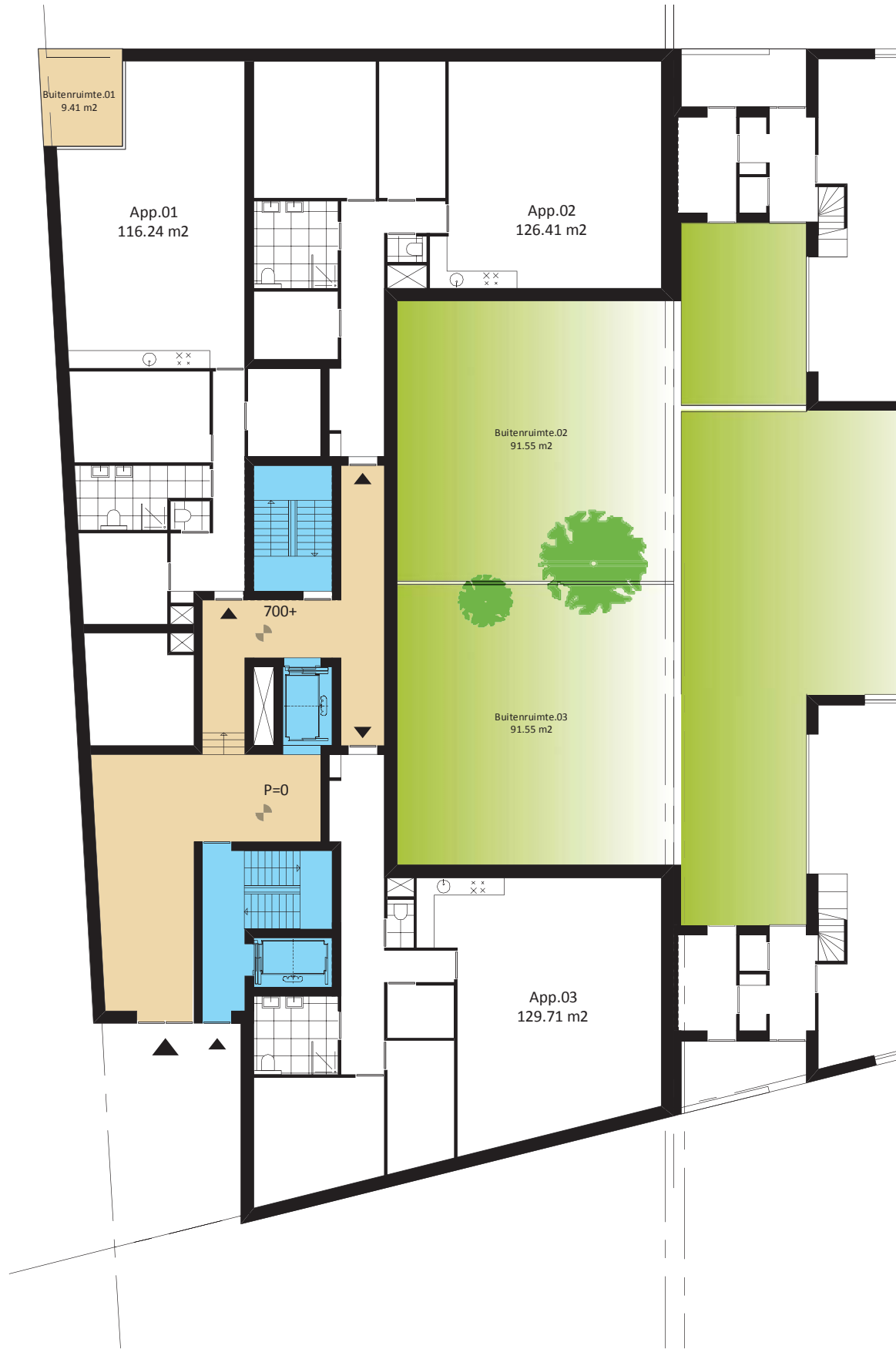

Begane grond interne parkeerverbinding

- + Interne verbinding blok A en parkeergarage
- Verbindingstunnel parkeergarage nodig



Begane grond externe parkeerverbinding

- Geen directe verbinding blok A en parkeergarage
- + Komt direct in parkeergarage uit

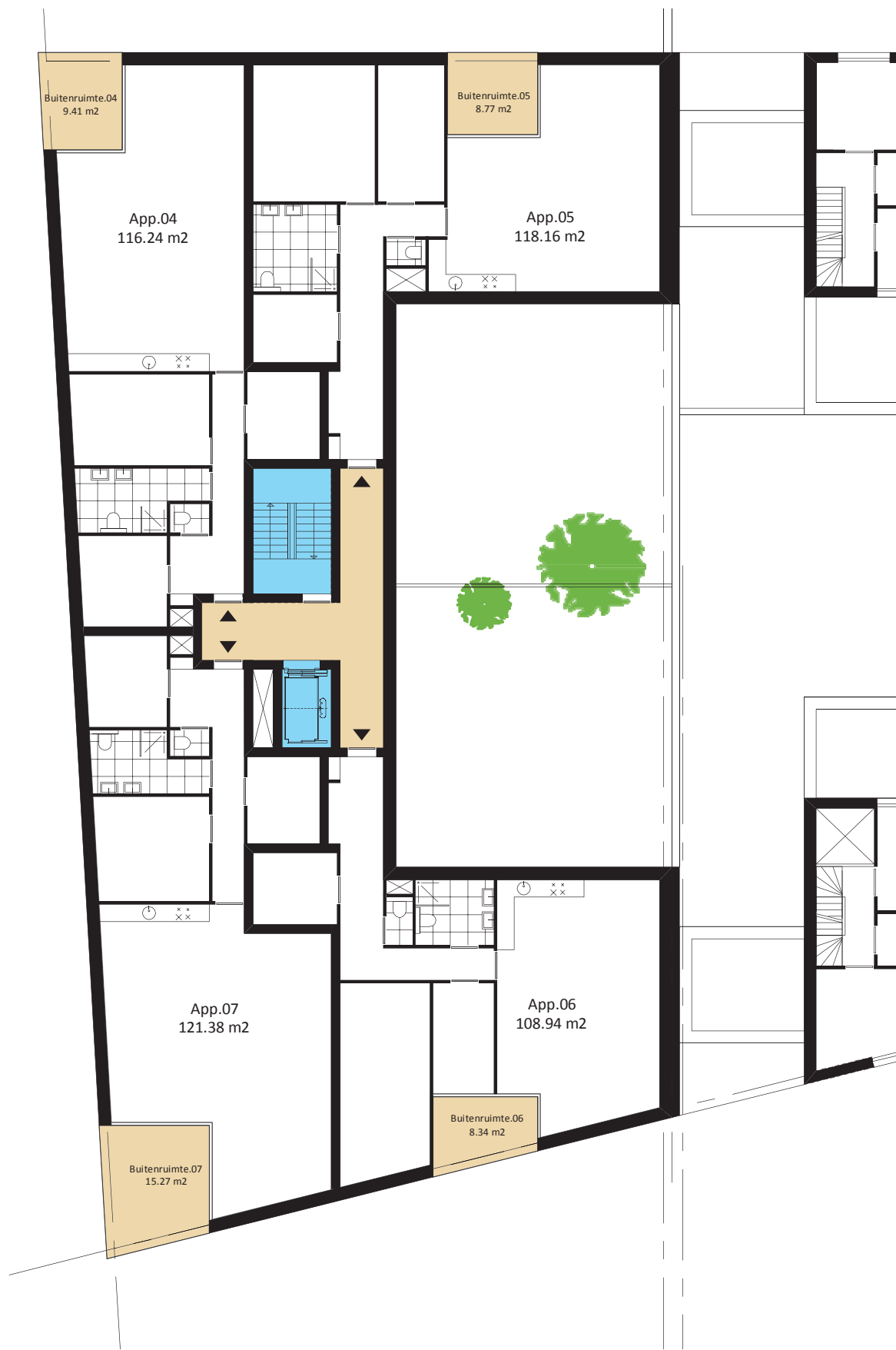

1e en 2e verdieping



3e verdieping



IMPRESSIE BLOK A



IMPRESSIE KLEVARIERREIN



COLOFON

Onderwerp : Klevarie Maastricht
projectomschrijving : visie Klevarie terrein- blok A
Projectnummer : 0253657

Datum : 08 December 2016

Omschrijving	Team	PL	Validatie
Definitief	as mw	mw	as



Wim Duisenbergplantsoen 21
Postbus 959
6200 AZ Maastricht
+31 (0) 43 3253223

Beneluxweg 125
Postbus 40
4900 AA Oosterhout
+31 (0)162 487500

info@croonenburo5.com
www.croonenburo5.com

